



ILLUMINATED products

NEW!

All of Furnitubes display cases are available illuminated. A lighting kit is supplied with the case to be fitted inside.

These kits can be used with wall mounted and post mounted display cases. One kit can be used at the top of the case, or a second kit can be used at the bottom of the case for added impact. For display case details see pages 281 and 289.

LED UPLIGHTERS

In addition to illuminated display cases, Furnitubes also supply LED uplighters which can be used to light up many of our products, from bollards and litter bins to seats. Available in three sizes with an array of options, including materials and light colour.



▲ LED 150
shown with the **DISTRICT Traffic Bollard** (see page 35)
installed at Shepherds Bush, London



▲ LED 035
options shown:
■ stainless steel flat edge (left)
■ brass body flat edge (centre)
■ stainless steel bevel edge (right)

▲ LED 2525
40x LED lights

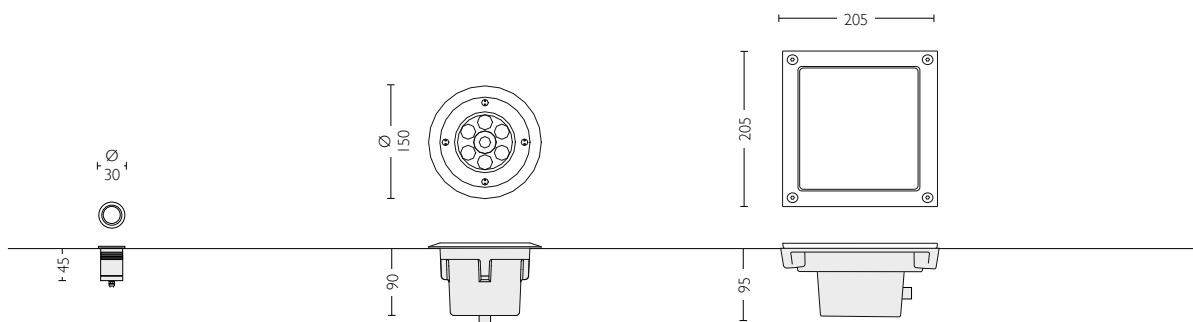

TECHNICAL

Illuminated Display Cases

Electrical wiring must be installed by a qualified person to comply with applicable safety regulations. The cable exit is not pre-defined in order that the installer may choose the most suitable position.

LED Colour Options

The following colour options are available:

White
Blue
Cyan
Green
Red
Orange
Yellow



Insulation Sleeve

The LEDs are available with an optional insulation sleeve, as shown with the LED 150 below. Insulation sleeve,

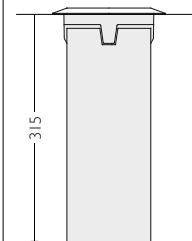

An insulation sleeve allows easy removal of the lighting unit if a replacement is needed. The sleeve can be pre-set in concrete, enabling the addition of the lighting unit at a later date.

Product Codes are in **bold type**. Dimensions are in mm, are approximate and do not form any part of the contract.

We reserve the right to change the design and specification on any item offered and, where possible, notification will be made.

LED UPLIGHTERS

LED 035

IP67 Rated
9x LED Lights (0.7w Power Consumption)
Stainless Steel Body
Stainless Steel Bevel Edge
Reinforced Glass Lens
Die Cast Aluminium Body
Supplied with 2m Cable

OPTIONS:

Stainless Steel Flat Edge
Brass Body & Bevel or Flat Edge
Chrome Body & Bevel or Flat Edge
Insulation Sleeve
Water Proof Connector (For Underground Connection)

LED 150

IP67 Rated
6x LED Lights (6w Power Consumption)
Stainless Steel Bevel Edge
Reinforced Glass Lens
Die Cast Aluminium Body
Supplied with 2m Cable

OPTIONS:

Stainless Steel Flat Edge
Brass Bevel Flat Edge
Chrome Body & Bevel Flat Edge
Insulation Sleeve
Water Proof Connector (For Underground Connection)

LED 2525

IP67 Rated
40x LED Lights (4w Power Consumption)
Powder Coated Edge
Reinforced Faceted Glass Lens
Die Cast Aluminium Body
Supplied with 1m Cable

OPTIONS:

24x Led Lights (4w Power Consumption)
140x Led Lights (6w Power Consumption)
Insulation Sleeve
Water Proof Connector (For Underground Connection)

