

▼ COLLEGE Root Fixed Galvanised Finish installed at Austin Court, Basingstoke



COLLEGE *cycle stand*

The College steel cycle stands are a popular choice due to their timeless appearance, great value and low maintenance finish.

These durable, easy to maintain stands can be bolted down or root fixed, and are available in galvanised steel and stainless steel. For extra strength, a larger diameter can be specified.

The College stands are the most economical on the market today and are usually available from stock. They can also be offered with a hardwearing plastic coated finish in a range of colours.



▲ COLLEGE Root Fixed
satin polished stainless steel
installed at Beaufort Park,
Hendon, London



▲ COLLEGE Bolt Down
galvanised steel
shown at West Middlesex University Hospital, Isleworth

OPTIONS

- galvanised steel
- stainless steel - bright or satin polished
- plastic coated finish
- bolt down or root fixed



▲ COLLEGE Root Fixed
black plastic coated
installed in Hereford



▲ COLLEGE Toast Rack
satin polished stainless steel
as supplied to the City of London School for Girls, Barbican

Individual stands enable a number of installation configurations. For example, stands can be angled, as shown, to reduce the amount of width that cycles occupy.

Alternatively stands can be supplied welded together to form a 'toast rack' that is ideal for locations where the unit is required to be free-standing or for speed of installation. Please call our Sales Department to discuss your site requirements.

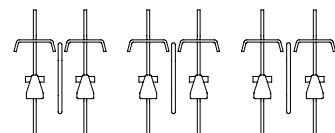

▲ COLLEGE
installed for minimum bay length

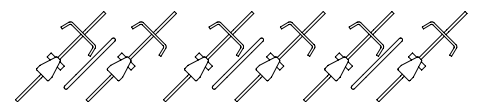

▲ COLLEGE
installed for minimum bay width



COLLEGE RANGE

TECHNICAL



Material
Furnitubes steel and stainless steel cycle stands are 100% recyclable.

Note 1

Plastic Coating
College cycle stands are available galvanised with a hardwearing plastic coating which offers a high degree of durability and vandal resistance. Available in the following colours:

- RAL 9016 - White
- RAL 1021 - Yellow
- RAL 5015 - Blue
- RAL 3020 - Red
- RAL 6005 - Green
- RAL 8017 - Brown
- RAL 7001 - Grey
- RAL 9005 - Black

For further information on paint finishes refer to pages 337-339.

Note 2

Satin Polish
The Stainless Steel version of the College can also be polished to a Satin Finish upon request.

Note 3

Base Plate
The optional base plate is 6mm thick and has the dimensions as follows:

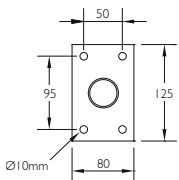

For cycle stands with a taper bar see the Zenith (pg 89), TFL and Hammersmith (pg 97).



More Toast Racks available on page 93.



Product Codes are in **bold type**. Dimensions are in mm, are approximate and do not form any part of the contract.

We reserve the right to change the design and specification on any item offered and, where possible, notification will be made.

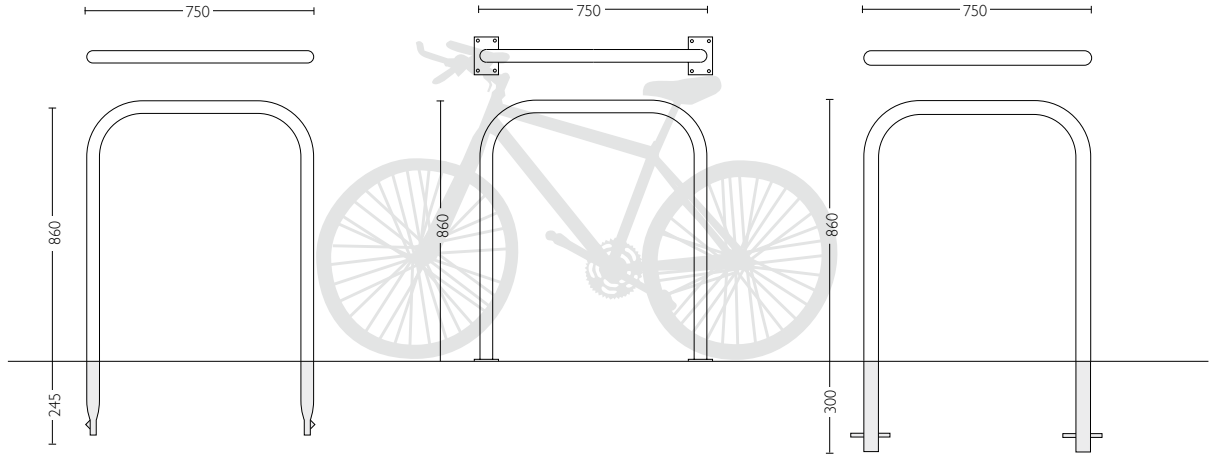

COLLEGE — ROOT FIXED		COLLEGE — BOLT DOWN		COLLEGE — HEAVY DUTY	
CSG 650 Ø42 Steel Galvanised Finish	CSS 650 BP Ø38 Stainless Steel Bright Polished Finish	CSG 650 B Ø42 Steel Galvanised Finish	CSS 650 B BP Ø38 Stainless Steel Bright Polished Finish	CSG 665 Ø48 Steel Galvanised Finish	
OPTIONS: Plastic Coated Finish	OPTIONS: Satin Polished Finish	OPTIONS: Plastic Coated Finish	OPTIONS: Satin Polished Finish	OPTIONS: Plastic Coated Finish Stainless Steel	
See Note 1	See Note 2	See Note 1 & 3	See Note 2 & 3	See Note 1	

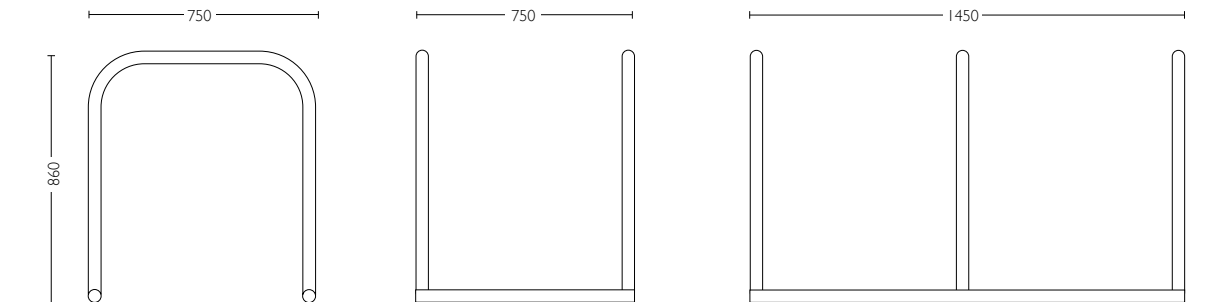

COLLEGE — TOAST RACK VARIATIONS		COLLEGE — TOAST RACK VARIATIONS	
Steel, Galvanised Finish	CTG 602 2 stands - 750mm length (as shown)	CTG 603 3 stands - 1450mm length (as shown)	
OPTIONS: Stainless Steel, Bright Polished Finish Stainless Steel, Satin Polished Finish			

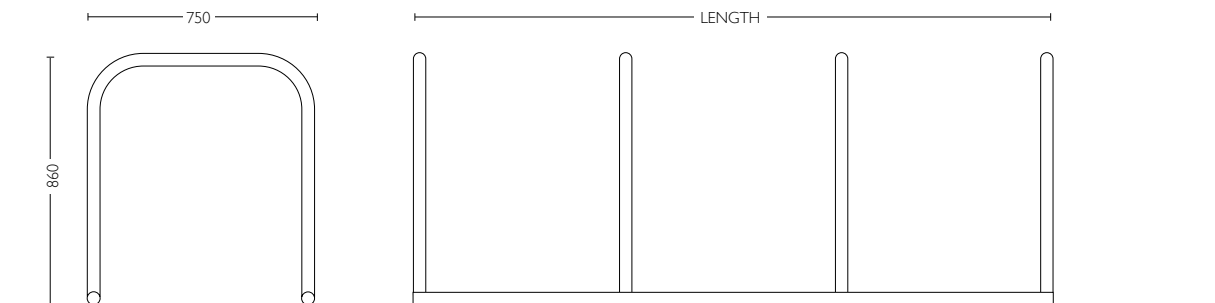

COLLEGE — TOAST RACK VARIATIONS		COLLEGE — TOAST RACK VARIATIONS	
Steel, Galvanised Finish	CTG 604 4 stands - 2150mm length (as shown)	CTG 605 5 stands - 2840mm length	
OPTIONS: Stainless Steel, Bright Polished Finish Stainless Steel, Satin Polished Finish			

Zenith[®] cycle stand



The stainless steel Zenith[®] Cycle Stand is the latest addition to the Zenith[®] range.

Its 48mm diameter construction makes it considerably stronger than many cycle stands, with a fully welded taper rail to offer additional strength, locking opportunities and assist detection by the visually impaired.

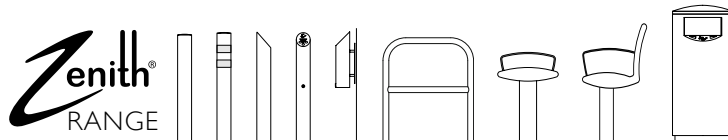

bollards
pg 50

seating
pg 182

litter
pg 228 & 245

signage
pg 276

▲ ZENITH
satin polished stainless steel
installed in LB Hammersmith



OPTIONS

- galvanised steel
- stainless steel - bright or satin polished
- plastic coated finish
- bolt down or root fixed

◀ ZENITH
satin polished stainless steel
installed in LB Hammersmith

TECHNICAL



Material
Furnitubes steel and stainless steel cycle stands are 100% recyclable.

Plastic Coating
The Zenith cycle stand is available plastic coated in the following colours:

- RAL 9016 - White
- RAL 1021 - Yellow
- RAL 5015 - Blue
- RAL 3020 - Red
- RAL 6005 - Green
- RAL 8017 - Brown
- RAL 7001 - Grey
- RAL 9005 - Black

For further information on paint finishes refer to pages 337-339.

Disability Conscious
Tapper bars can aid the visually impaired.



Product Codes are in **bold type**. Dimensions are in mm, are approximate and do not form any part of the contract.

We reserve the right to change the design and specification on any item offered and, where possible, notification will be made.

related products



college pg 86



hammersmith pg 96



TFL 600 pg 97

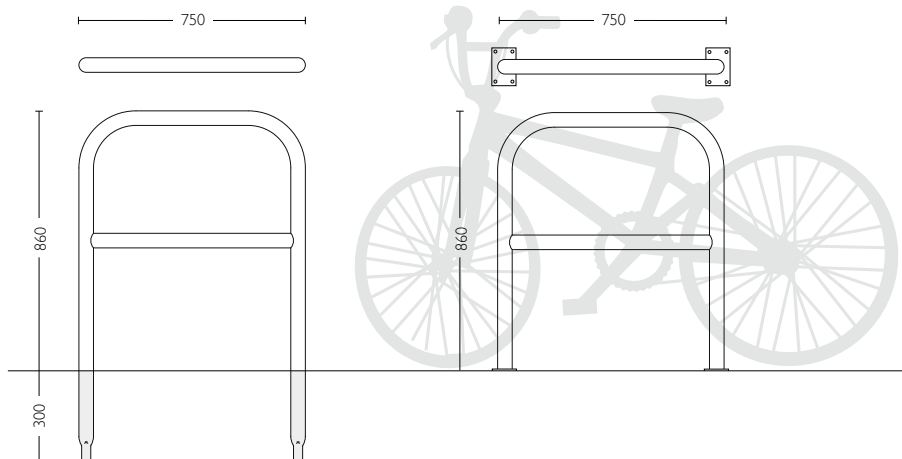

ZENITH - ROOT FIXED		ZENITH - BOLT DOWN	
ZEN 650 Ø48 Steel Galvanised Finish	ZEN 650 BP Ø48 Stainless Steel Bright Polished	ZEN 650 B Ø48 Steel Galvanised Finish	ZEN 650 B BP Ø48 Stainless Steel Bright Polished
OPTIONS: Plastic Coated	OPTIONS: Satin Polished	OPTIONS: Plastic Coated	OPTIONS: Satin Polished





FIN

cycle stand



▲ **FIN 600 Root Fixed**
satin polished stainless steel
supplied to Burdett Park, Mile End, London



The contemporary shape of the Fin cycle stand was designed for the Millennium.

This distinctive cycle stand is manufactured in heavy-duty steel sections. The Fin is unique in design and durable to withstand the rigours of frequent use.

Available in steel and stainless steel with a range of finishes and options including root fixed and bolt down.



▲ **FIN 480 Root Fixed**
galvanised steel with decorative corner plate
shown at the Eden Project, Cornwall

◀ **FIN 600 Bolt Down**
bright polished stainless steel
with decorative corner plate

The Fin range is available in two sizes and a decorative corner plate is available as an extra option to secure bikes to the stand. The plate can also be fitted with a plaque for sponsorship, see page 107 for more details.

To tie in with town schemes, stands can be plastic coated to create visual harmony.

OPTIONS

- galvanised steel
- stainless steel - bright or satin polished
- plastic coated finish
- bolt down
- root fixed
- decorative corner plate



▲ **FIN 600 Root Fixed**
satin polished stainless steel with decorative corner plate
turquoise vinyl yacht logo with anti-graffiti coating
installed on Canvey Island, Essex



▲ **Turquoise Vinyl Yacht Logo**

FIN RANGE



For promotion options with the use of a sponsorship plate, see page 107.



▲ **FIN 480 - Stainless Steel**
bright polished finish
shown at UCE Birmingham



▲ **FIN 600 - Stainless Steel**
satin polished finish with decorative corner plate
installed at Leyton Orient Football Club, Barking, Essex

TECHNICAL



Material
Furnitubes steel and stainless steel cycle stands are 100% recyclable.

Note 1

Plastic Coating
Hardwearing, high degree of durability and vandal resistance. Available in the following colours:

- RAL 9016 - White
- RAL 1021 - Yellow
- RAL 5015 - Blue
- RAL 3020 - Red
- RAL 6005 - Green
- RAL 8017 - Brown
- RAL 7001 - Grey
- RAL 9005 - Black

For further information on paint finishes refer to pages 337-339.

Note 2

Decorative Corner Plate
When ordering the Fin, please specify if a decorative corner plate is required.

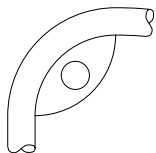

Product Codes are in **bold type**. Dimensions are in mm, are approximate and do not form any part of the contract.

We reserve the right to change the design and specification on any item offered and, where possible, notification will be made.

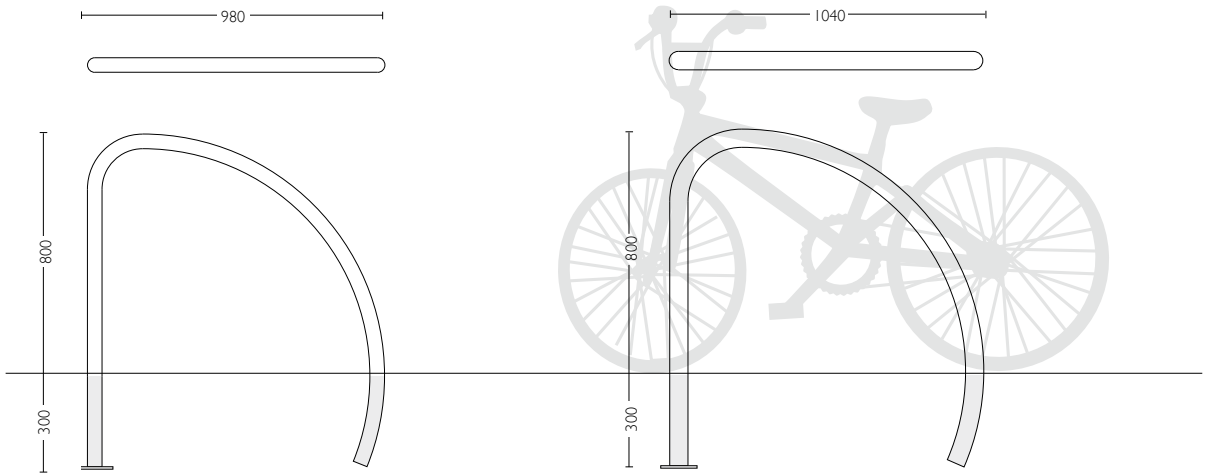

FIN - ROOT FIXED

FIN 480
Ø48 Steel, Galvanised Finish

OPTIONS:
Plastic Coated Finish

See Note 1

FIN 480 BP
Ø48 Stainless Steel Bright Polished

OPTIONS:
Satin Polished Finish

FIN - ROOT FIXED

FIN 600
Ø60 Steel, Galvanised Finish

OPTIONS:
Plastic Coated Finish
Decorative Corner Plate

See Notes 1 & 2

FIN 600 BP
Ø60 Stainless Steel Bright Polished

OPTIONS:
Satin Polished Finish
Decorative Corner Plate

See Note 2

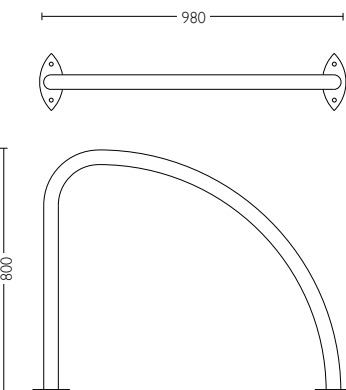

FIN - BOLT DOWN

FIN 480 B
Ø48 Steel, Galvanised Finish

OPTIONS:
Plastic Coated Finish

See Note 1

FIN 480 B BP
Ø48 Stainless Steel Bright Polished

OPTIONS:
Satin Polished Finish

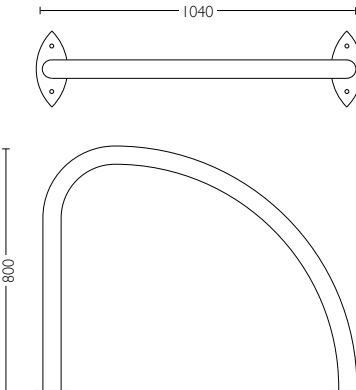

FIN - BOLT DOWN

FIN 600 B
Ø60 Steel, Galvanised Finish

OPTIONS:
Plastic Coated Finish
Decorative Corner Plate

See Notes 1 & 2

FIN 600 B BP
Ø60 Stainless Steel Bright Polished

OPTIONS:
Satin Polished Finish
Decorative Corner Plate

See Note 2

MODULAR TOAST

rack

The unique shape of the Modular Toast Rack is ideal for schools play areas.

Available in steel and stainless steel, the rack is durable and low maintenance. The freestanding bolt down stand is quick and easy to install, making it ideal for inside cycle shelters.

The College Toast Rack is also available, see pages 87-88.

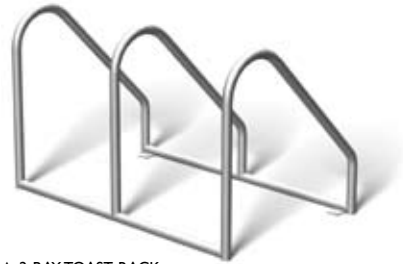

▲ 2-BAY TOAST RACK
stainless steel satin polished finish



▲ 3-BAY TOAST RACK
stainless steel satin polished finish

Toast racks can be placed next to each other to create 5, 6 and 7 bay cycle racks.



▲ 5-bay configuration

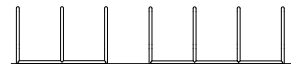

▲ 6-bay configuration



▲ 7-bay configuration

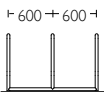

MOD 206
600mm Centres

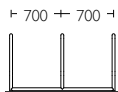

MOD 207
700mm Centres

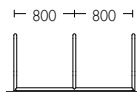

MOD 208
800mm Centres

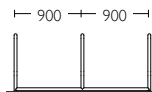

MOD 209
900mm Centres

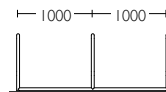

MOD 210
1000mm Centres

▲ 2-BAY TOAST RACK

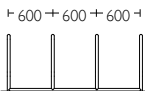

MOD 306
600mm Centres

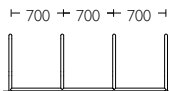

MOD 307
700mm Centres

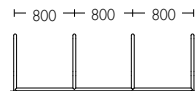

MOD 308
800mm Centres

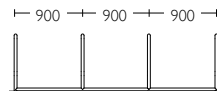

MOD 309
900mm Centres

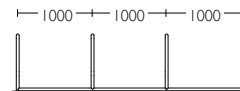

MOD 310
1000mm Centres

▲ 3-BAY TOAST RACK

TECHNICAL



Material
Furnitubes steel and stainless steel cycle stands are 100% recyclable.

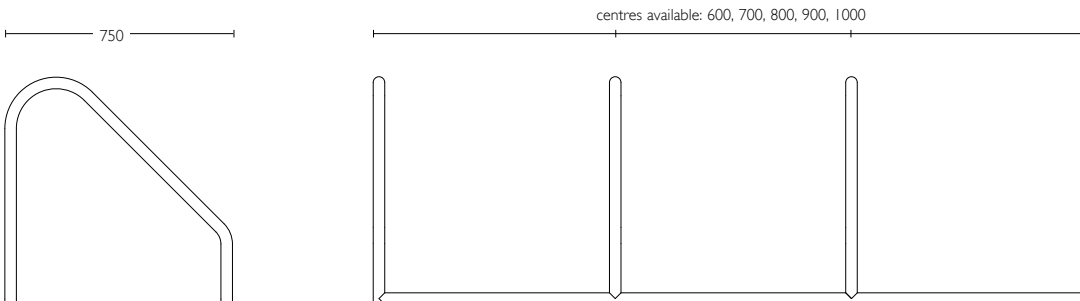

MODULAR TOAST RACK - 3-BAY

CODE

Stainless Steel, Satin Polished
Different Centre Lengths Available (see above)

OPTIONS:

Galvanised Steel
2-Bay Toast Rack

Product Codes are in **bold type**. Dimensions are in mm, are approximate and do not form any part of the contract.

We reserve the right to change the design and specification on any item offered and, where possible, notification will be made.



NORDIC & HOOP

cycle stands

The steel Hoop & Nordic cycle stands use loops and curves to create fun and dynamic shaped stands.

The **Nordic** cycle stand is available in three sizes with two, three or four loops. All are root fixed with a galvanised finish.

The compact **Hoop** cycle stand is available in galvanised steel, galvanised and plastic coated steel, and stainless steel.



▲ **NORDIC**
galvanised steel



▲ **HOOP**
stainless steel
installed at Commercial Street, Nelson Town Centre,
The Vale of Glamorgan, Wales



▲ **NORDIC**
black plastic coated
shown at Hounslow High Street, London

TECHNICAL



Material
Furnitubes steel and stainless steel cycle stands are 100% recyclable.

Plastic Coating
Hardwearing, high degree of durability and vandal resistance. Available in the following colours:

- RAL 9016 - White
- RAL 1021 - Yellow
- RAL 5015 - Blue
- RAL 3020 - Red
- RAL 6005 - Green
- RAL 8017 - Brown
- RAL 7001 - Grey
- RAL 9005 - Black

For further information on paint finishes refer to pages 337-339.

Product Codes are in **bold type**. Dimensions are in mm, are approximate and do not form any part of the contract.

We reserve the right to change the design and specification on any item offered and, where possible, notification will be made.

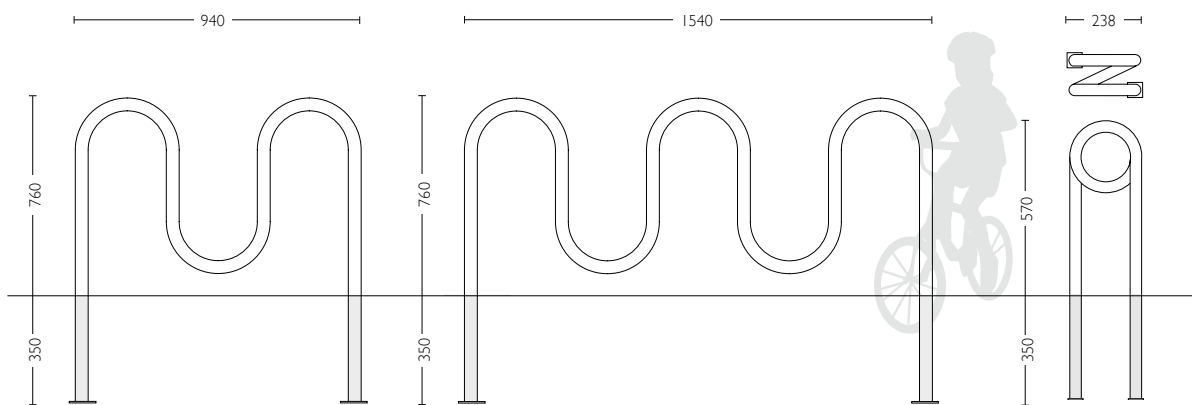

NORDIC
NOR 303
TYPE A - 940mm long with 2 loops
Root Fixed, Ø48 Steel, Galvanised Finish

OPTIONS:
TYPE B - 1540mm long with 3 loops
TYPE C - 2140mm long with 4 loops
Plastic Coated Finish

NORDIC
NOR 303
TYPE B - 1540mm long with 3 loops (as shown)
Root Fixed, Ø48 Steel, Galvanised Finish

OPTIONS:
TYPE A - 940mm long with 2 loops
TYPE C - 2140mm long with 4 loops
Plastic Coated Finish

HOOP
HSG 800
Steel, Galvanised Finish

OPTIONS:
Galvanised & Plastic Coated Finish
Stainless Steel, Bright Polished Finish

CYCLE & MOTORCYCLE

stands



The District Cycle Stand is a new addition to the District Range.

Available in three sizes in steel and stainless steel, its modern and simple profile compliments not only the rest of the **District** range but many more of Furnitubes products.

DISTRICT RANGE

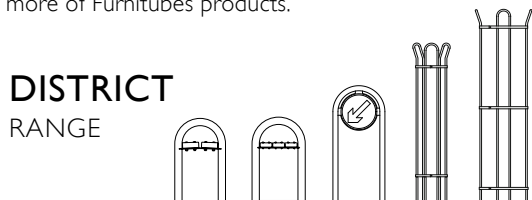

traffic bollards
pg 35



seating
pg 180



tree guards
pg 313

▲ **DISTRICT 350**
stainless steel bright polished

Furnitubes new **Harley** motorcycle stand enables users to secure their motorbike using their own chain or cable.

The Harley has a 20mm solid steel diameter, and features a chequered lid. When not in use the stand is discretely hidden in the ground.



▲ **HARLEY**
galvanised steel
the lid is discretely hidden in the ground when not in use

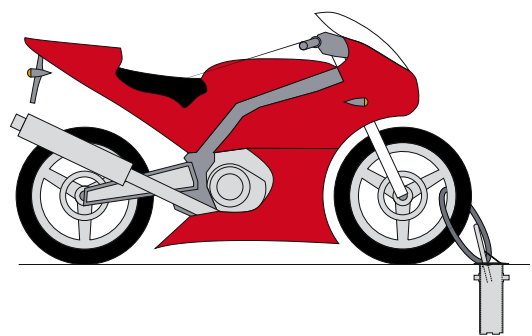

TECHNICAL



Material

Furnitubes steel and stainless steel cycle stands are 100% recyclable.

Plastic Coating

The District Cycle Stands are available plastic coated in the following colours:

- RAL 9016 - White
- RAL 1021 - Yellow
- RAL 5015 - Blue
- RAL 3020 - Red
- RAL 6005 - Green
- RAL 8017 - Brown
- RAL 7001 - Grey
- RAL 9005 - Black

For further information on paint finishes see pages 337-339.

Product Codes are in **bold type**. Dimensions are in mm, are approximate and do not form any part of the contract.

We reserve the right to change the design and specification on any item offered and, where possible, notification will be made.

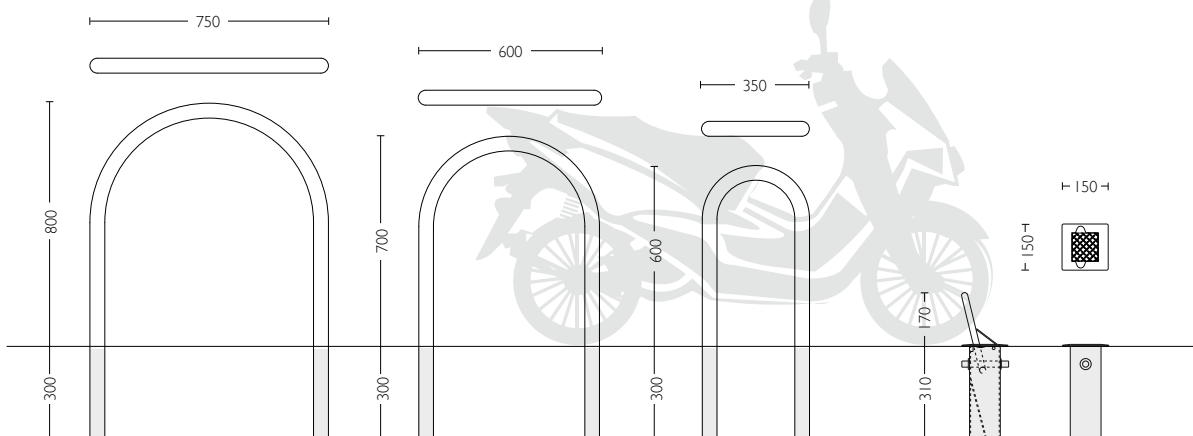

DISTRICT

DST 750

Ø48 Stainless Steel, Satin Polished

OPTIONS:

Stainless Steel, Bright Polished
Galvanised Steel
Plastic Coated
Ø60

DST 600

Ø48 Stainless Steel, Satin Polished

OPTIONS:

Stainless Steel, Bright Polished
Galvanised Steel
Plastic Coated
Ø60

DST 350

Ø48 Stainless Steel, Satin Polished

OPTIONS:

Stainless Steel, Bright Polished
Plastic Coated
Ø60

HARLEY

HAR 170

Root Fixed Motorcycle Stand
Steel, Galvanised Finish
20mm Loop Diameter

